

ORCA

Model number:
WD01

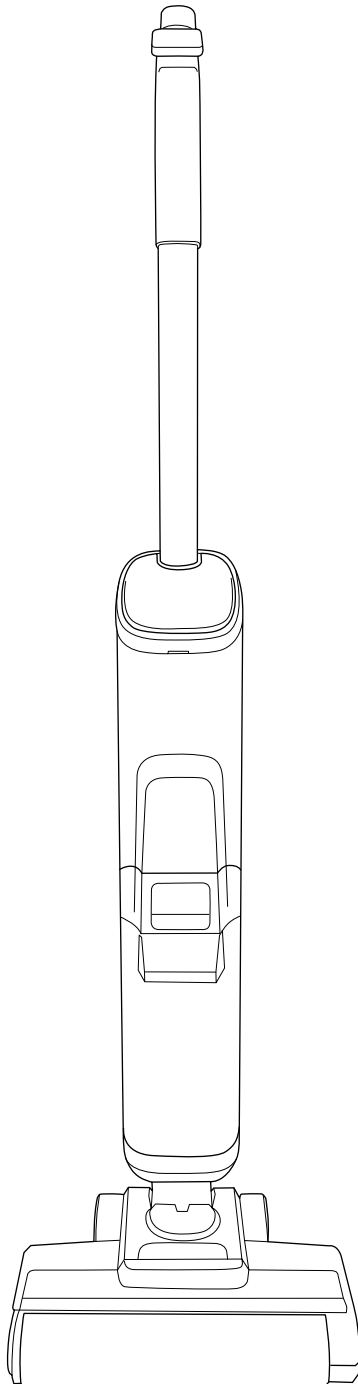

OPERATING MANUAL

IMPORTANT SAFEGUARDS:



**IMPORTANT: READ ALL INSTRUCTIONS BEFORE USE.
RETAIN INSTRUCTIONS FOR FUTURE REFERENCE.**



Do not use in rain or leave outdoors whilst raining.



WARNING: Basic safety precautions should always be observed when using an electrical appliance, including the following to reduce the risk of fire, electrical shock, or injury:

Personal Safety:

- Store indoors in a dry place out of the reach of children.
- Always use responsibly. This appliance can be used by children aged from 8 years and above and persons with reduced physical, sensory or mental capabilities or lack of experience and knowledge if they have been given supervision or instruction concerning use of the appliance in a safe way and understand the hazards involved.
- Don't let children play with the appliance; supervise children using or maintaining the appliance.
- Use only manufacturer's recommended attachments as described in this manual; misuse or use of any accessory or attachment other than those recommended, may present a risk of personal injury.
- Take extra care when cleaning stairs.
- Keep the appliance and accessories away from hot surfaces.
- Do not block the appliances openings or hinder air flow; keep openings free of any objects including dust, lint, clothing, fingers (and all parts of the body).
- Particularly keep hair away from openings and moving parts.

Electrical safety:

- Only use batteries and chargers supplied by Gtech.
- Never modify the charger in any way.
- The charger has been designed for a specific voltage. Always check that the mains voltage is the same as that stated on the rating plate. A charger that is suitable for one type of battery pack may create a risk of fire when used with another battery pack; never use the charger with another appliance or attempt to charge this product with another charger.

- Before use, check the charger cord for signs of damage or ageing. A damaged or entangled charger cord increases the risk of fire and electric shock.
- Do not abuse the charger cord.
- Never carry the charger by the cord.
- Do not pull the cord to disconnect from a socket; grasp the plug and pull to disconnect.
- Don't wrap the cord around the charger when storing.
- Keep the charger cord away from hot surfaces and sharp edges.
- The supply cord cannot be replaced. If the cord is damaged the charger should be discarded and replaced.
- Do not handle the charger or the appliance with wet hands.
- Do not store or charge the appliance outdoors.
- The charger must be removed from the socket before removing the battery, cleaning or maintaining the appliance.

Battery safety:

- This appliance includes Li-Ion batteries; **do not incinerate batteries or expose to high temperatures**, as they may explode.
- Liquid ejected from the battery may cause irritation or burns.
- In an emergency situation contact professional help immediately!
- Leaks from the battery cells can occur under extreme conditions. Do not touch any liquid that leaks from the battery. If the liquid gets on the skin wash immediately with soap and water. If the liquid gets into the eyes, flush them immediately with clean water for a minimum of 10 minutes and seek medical attention. Wear gloves to handle the battery and dispose of immediately in accordance with local regulations.

- Shorting the battery terminals may cause burns or fire.
- When the battery pack is not in use, keep it away from paper clips, coins, keys, nails, screws or other small metal objects that could make a connection from one terminal to another.
- Store the product away from any liquids and chemicals that may damage the battery and cause a risk of fire.
- Store the product in clean, dry conditions, within a recommended temperature range of 0 - 25°C
- Do not store the product in areas of high temperature above 25°C. Do not store near a source of heat or where exposed to direct sunlight.
- When you dispose of the appliance remove the battery and dispose of the battery safely in accordance with local regulations.

Service:

- Before using the appliance and after any impact, check for signs of wear or damage and repair as necessary.
- Do not use the appliance if any part is damaged or defective.
- Repairs should be carried out by a service agent or a suitably qualified person in accordance with relevant safety regulations. Repairs by unqualified persons could be dangerous.
- Never modify the appliance in any way as this may increase the risk of personal injury.
- Only use replacement parts or accessories provided or recommended by Gtech.

Intended use:

- This appliance has been designed for domestic hard floor cleaning only.
- Use only indoors, on non-carpeted sealed hard floor surfaces, for example vinyl, tiles, sealed wood, etc. The product is not intended to be used on carpeted floor surfaces.
- Use only as described in this manual.
- Do not use to pick up flammable or combustible liquids, ultrafine particles, sharp objects, hazardous material, chemicals or anything that is burning or smoking, as described above.
- Do not use to pick up hazardous materials and chemicals, such as solvents, drain cleaner,

strong acid or strong alkali solutions.

- Do not place or submerge the appliance in standing water or try to clean flooded areas.
- Don't use on concrete, tarmacadam or other rough surfaces.
- The brush bar may damage certain floor surfaces. Before cleaning flooring, check the flooring manufacturer's recommended cleaning instructions.
- The product has been designed to clean a wide variety of hard floor surfaces without the need to change settings. The product is not intended to be used on carpets, rugs, delicate fabrics, upholstery, or other types of soft floor coverings, and may cause damage. Care should be taken not to run over loose objects or the edges of rugs, loose weave carpets, and floor coverings where there are tassels or loose exposed threads. It is advised to test on an inconspicuous area first before use.
- The product has a constantly rotating mopping roller. Never leave the cleaning head in one spot for an extended period of time as this may damage the floor surface.
- Particularly for hard flooring, before cleaning check the area being cleaned is free of any hard debris or objects that could damage the flooring if caught underneath the product, and that the underside of the product is free from foreign objects that could mark the surface.
- Only use the Gtech recommended cleaning solution. Test on small inconspicuous areas prior to use. Do not mix with other cleaning substances or fluids. Do not use cleaning products such as washing up liquid, carpet cleaners, bleach, or any other cleaning substances or fluids that may damage the product.
- Do not use boiling water.

WARNING:

- **Do not use water, solvents, or polishes to clean the outside of the appliance; wipe clean with a dry cloth.**
- **Never immerse the unit in water and do not clean in a dish washer.**
- **Never use the appliance without both water tanks fitted.**
- **FOR HOUSEHOLD USE ONLY**



Thank you for choosing Gtech

"Welcome to the Gtech family. I started Gtech to create sensible, easy to use products that do a great job, and hope you get many years of trouble-free performance from your new product."

Nick

Nick Grey – Inventor, owner of Gtech

Make a note of your product serial number code for future reference.
You can find this on the back of the product behind the clean water tank

~ ~ ~ ~ ~ ~ ~ ~
~ ~ ~ ~ ~ ~ ~ ~
~ ~ ~ ~ ~ ~ ~ ~
~ ~ ~ ~ ~ ~ ~ ~

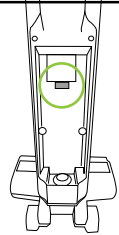

What's in the box

- 1 Main body
- 2 Handle
- 3 Clean water tank
- 4 Waste water tank
- 5 Mopping roller
- 6 Accessories holders
- 7 Charging base
- 8 Charger
- 9 Cleaning solution
- 10 Cleaning tool

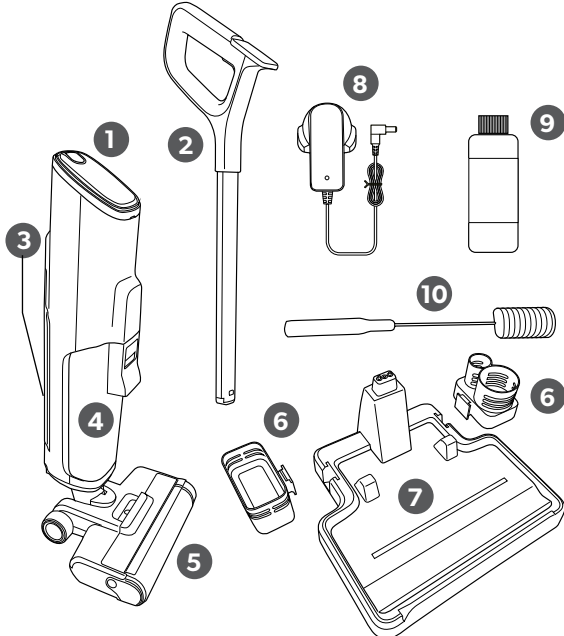

Assembly

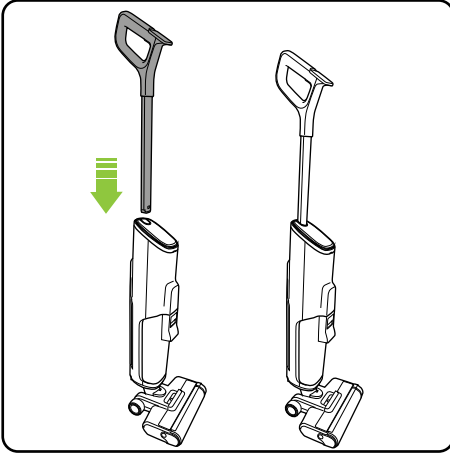

Insert the handle into the main body. It will click into place. The handle includes the screen. Note the direction of the handle.

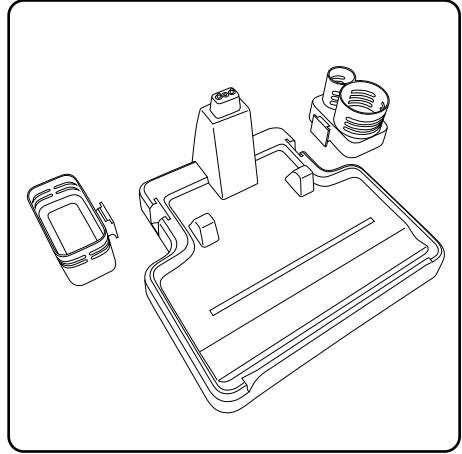

Place the accessory holders on the charging base.

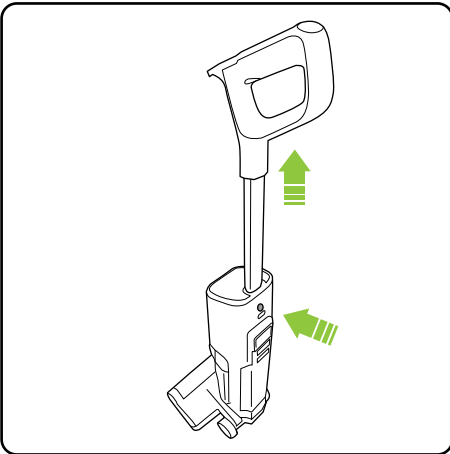

The handle can be removed by using a suitable tool to press and release the latch in the round hole in the rear of the body, and then pulling the handle upwards

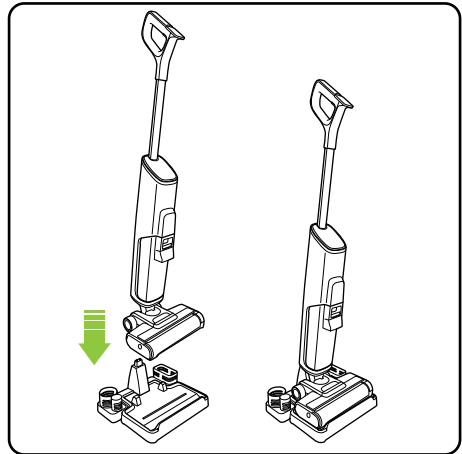

The Orca can be placed on the charge base to charge the battery (page 10), for self-cleaning (page 11), and storage

Fill clean water tank

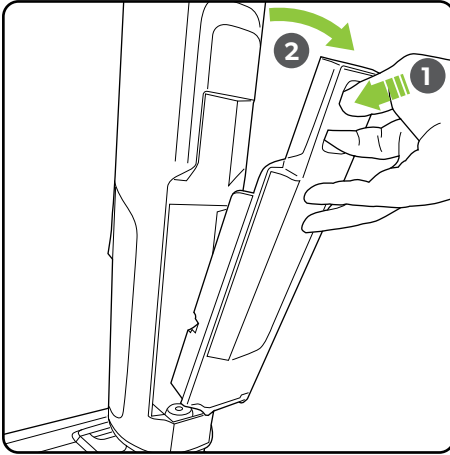

Before first use fill the clean water tank. Press the latch and remove the clean water tank from the rear of the Orca.

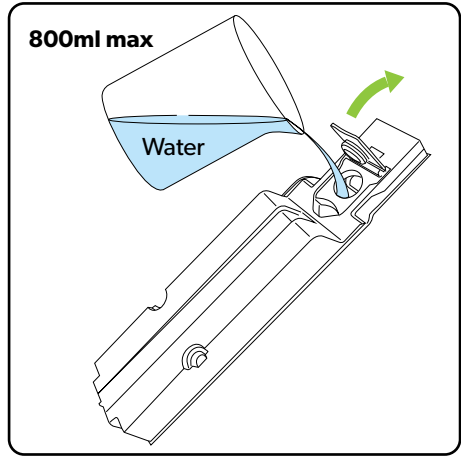

Lift the flap to add water to the tank. The floor cleaning solution can be added to the clean water tank if desired. Do not exceed the recommended dose.

Only use the Gtech recommended cleaning solution. Do not use cleaning products such as washing up liquid, carpet cleaners, bleach, or any other cleaning substances or fluids that may damage the product.

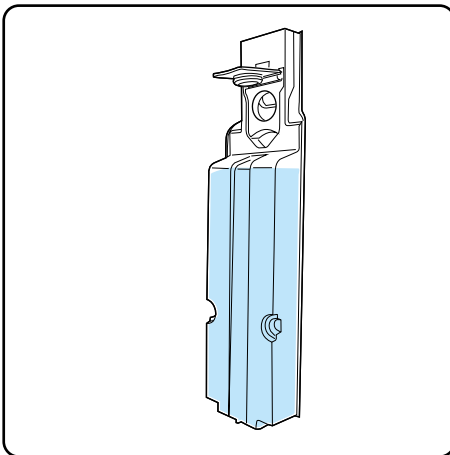

Do not fill the tank beyond the MAX level marked on the tank.

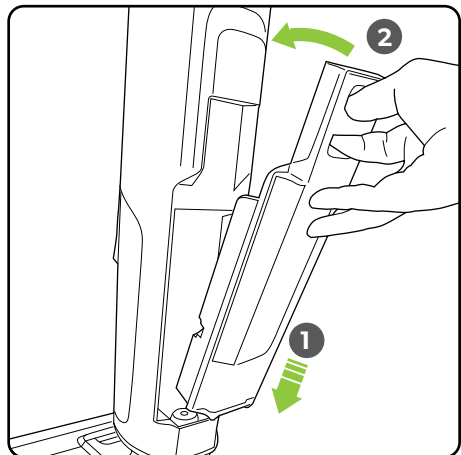

To replace the clean water tank, put the bottom of the tank in the Orca first then push the top in until it clicks shut.

Warning: do not use the Orca without both water tanks fitted.

Operation

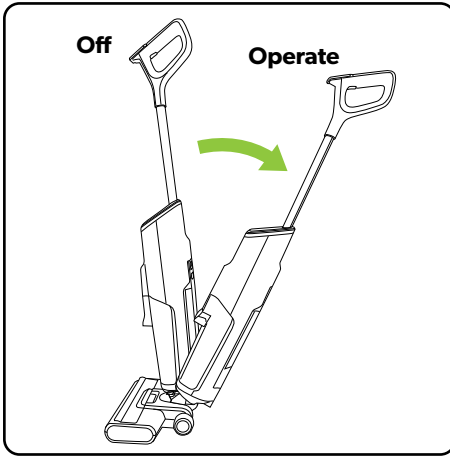

The Orca will not start in the upright position. To use put your foot on the head and pull the handle back.

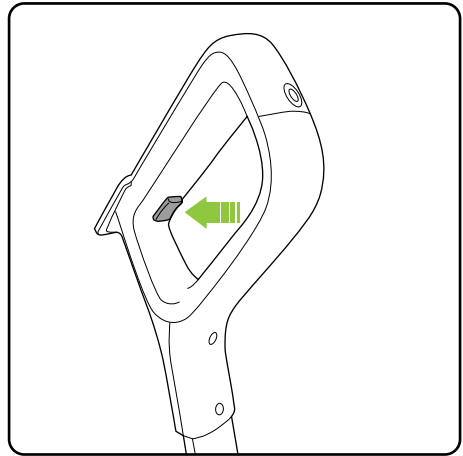

The power on/off button is located underneath the screen on the upper handle. Press and hold the power button until the Orca **starts** and the LCD display comes on. Once started the button can be released.

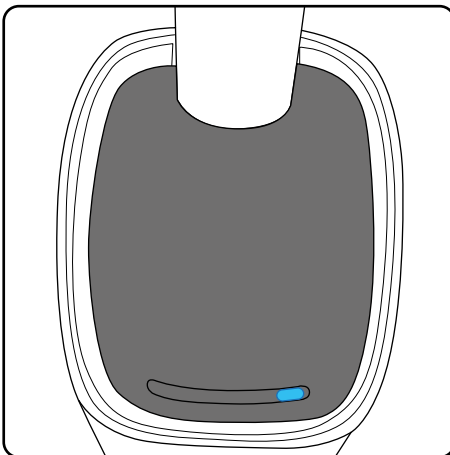

To switch off press and hold the power button until the Orca **stops** and the LCD display goes off. A single blue light will be displayed

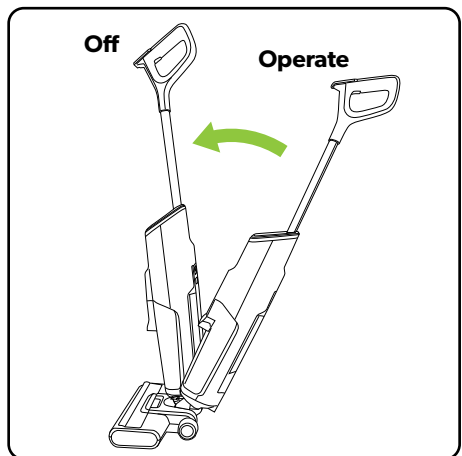

If the Orca is put into the upright position during use it will automatically power off. To re-start follow the actions above.

Using the screen

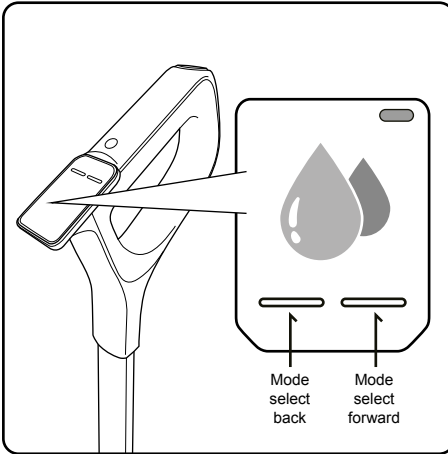

Pressing the on/off button activates the LCD screen. The buttons cycle forward and backwards through the different modes.

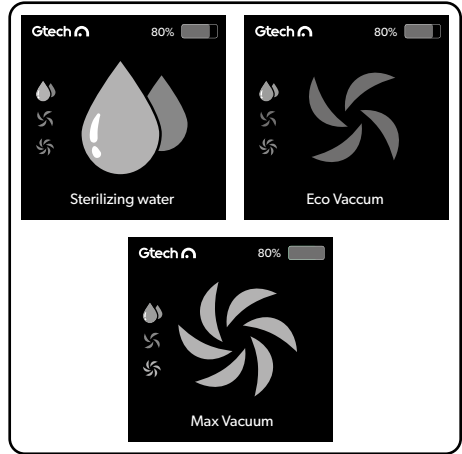

The current mode will display on the screen.

Function modes

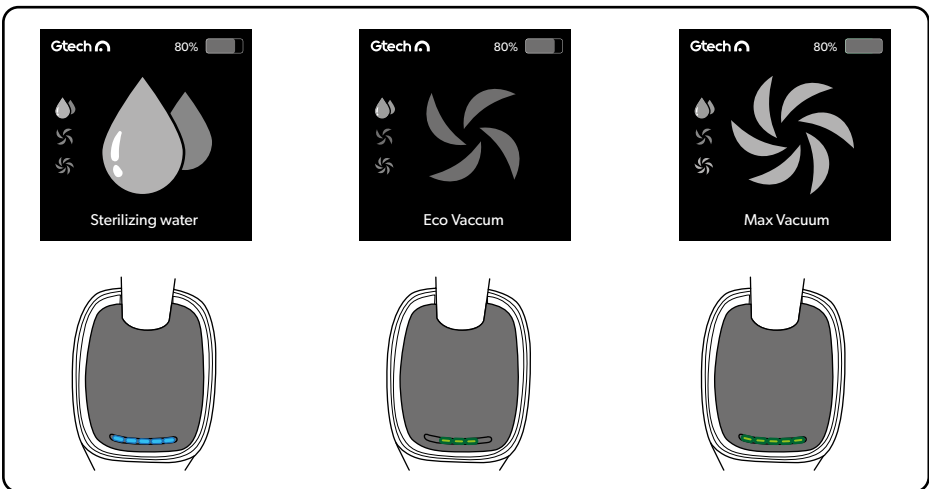

Sterilizing water – water is dispensed and collected. Use for cleaning the floor.

Eco Vacuum – no water dispensed, water collected, lower power for an extended run time. Use for drying the floor or picking up spills.

Max vacuum - no water dispensed, water collected, higher power with a shorter run time. Use for drying the floor or picking up spills.

Emptying the waste water tank



At this stage you may remove the waste water tank by unlatching it at the front of the unit. Press the latch and pull the waste water tank to remove from the Orca.

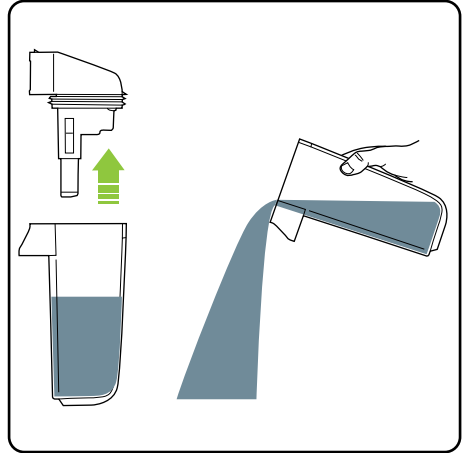

Remove the top section of the waste water tank and pour away the waste water.

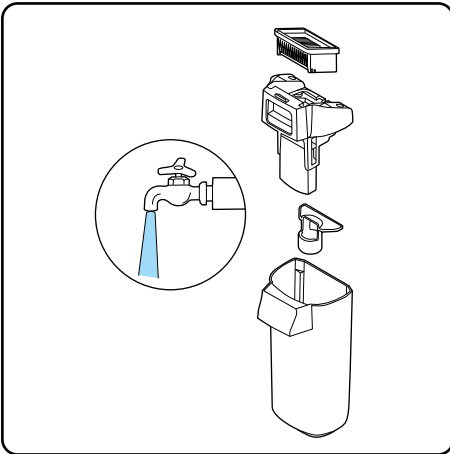

After rinsing the parts, leave them to dry.

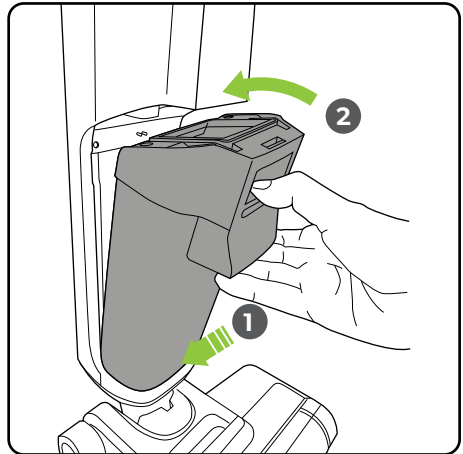

Locate the bottom of the waste water tank into the Orca and then firmly push the top until it clicks securely into place.

Warning: do not use the Orca without both water tanks fitted.

Charging

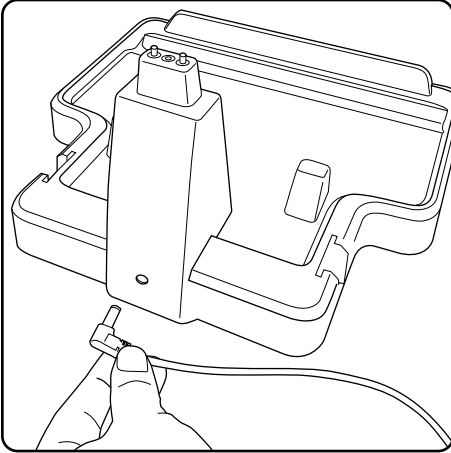

Position the charge base close to a plug socket and plug the charger into the back of the charge base as shown.

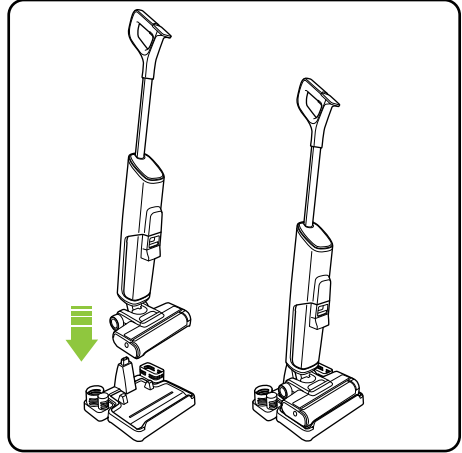

Place the Orca onto the charge base

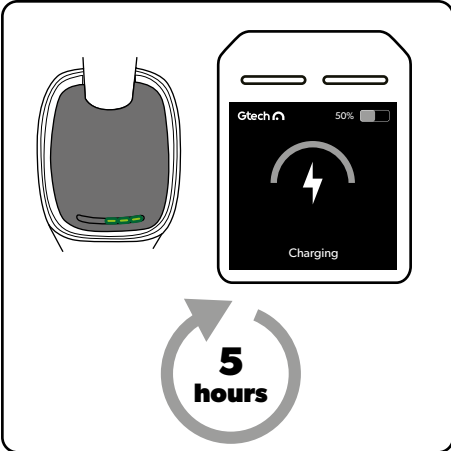

When charging the green lights will flash and light up in turn.
The LCD display will indicate charging

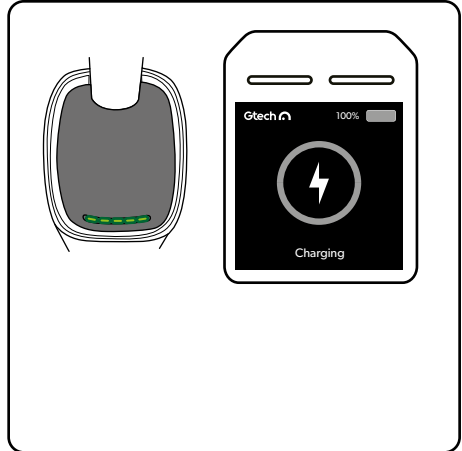

When fully charged the 5 green lights will be on.
The LCD display will show fully charged.

Self-cleaning mode

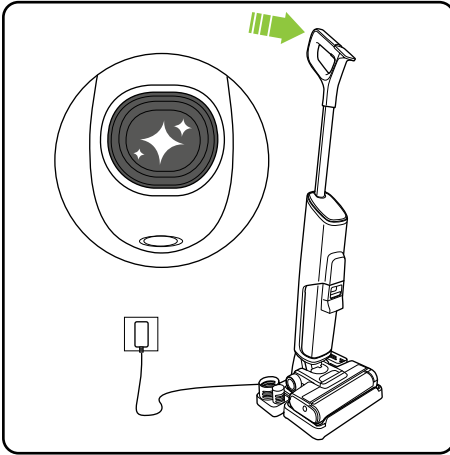

To clean the product after use, place the Orca into the stand and press the button at the top of the handle.

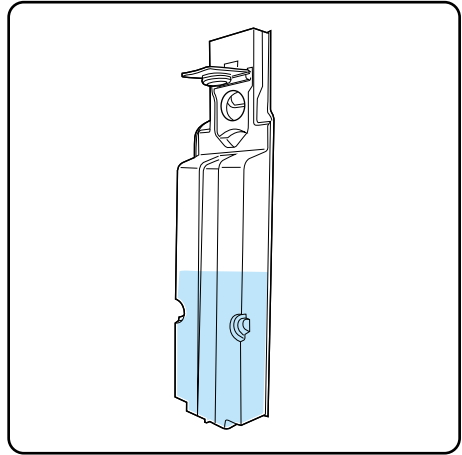

The clean water tank must be at least half full of water.

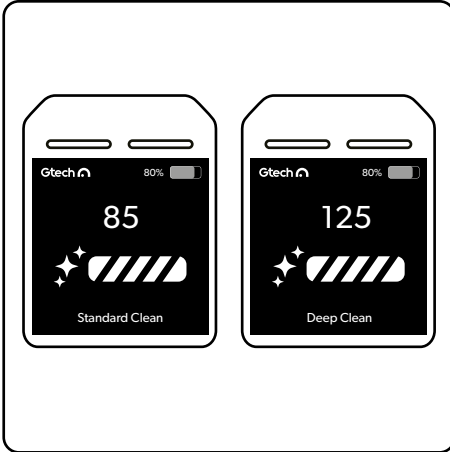

Use the buttons on the screen to choose from Standard Clean and Deep Clean. A countdown will display for seconds remaining.

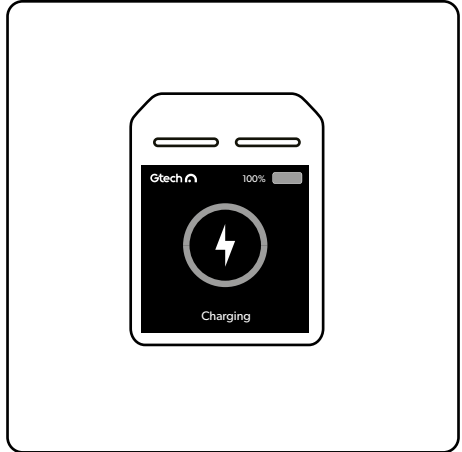

When the self-clean routine completed the charging symbol will appear on the screen. Remove and empty the waste water tank as shown on page 9.

Maintenance

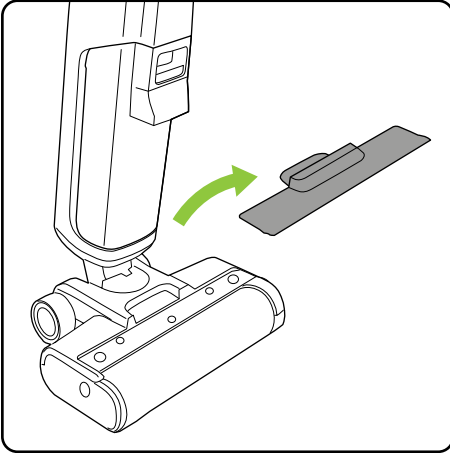

Lift off the roller cover.

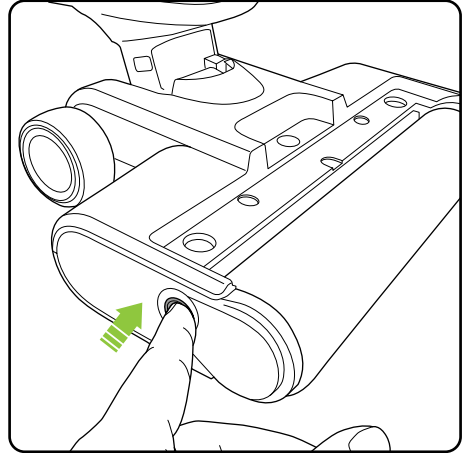

Press the button to release the mopping roller.

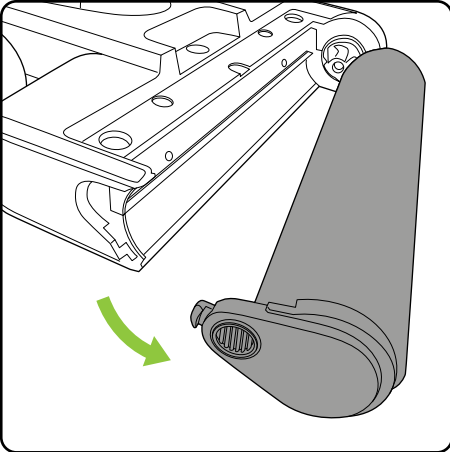

Pull the end cap of the mopping roller forward to remove.

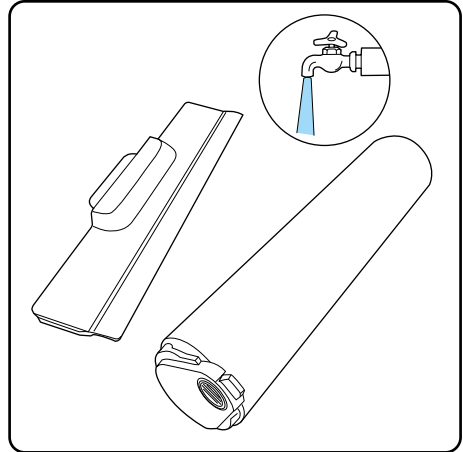

The roller cover and mopping roller can be washed under a tap.

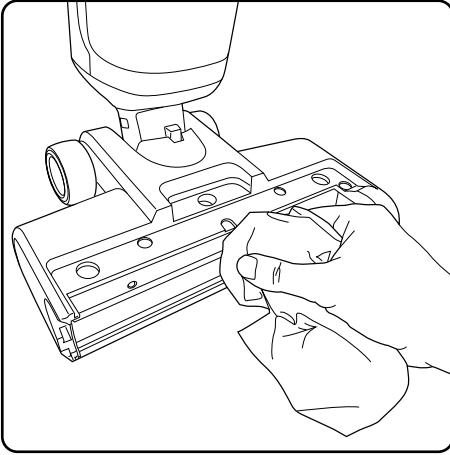

Take this opportunity to wipe down the rest of the Orca.

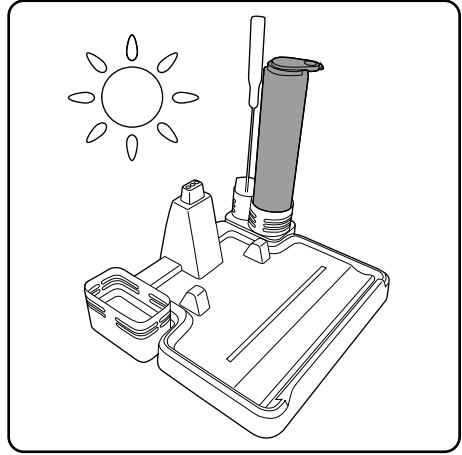

After washing the roller can be placed in the base to dry naturally.

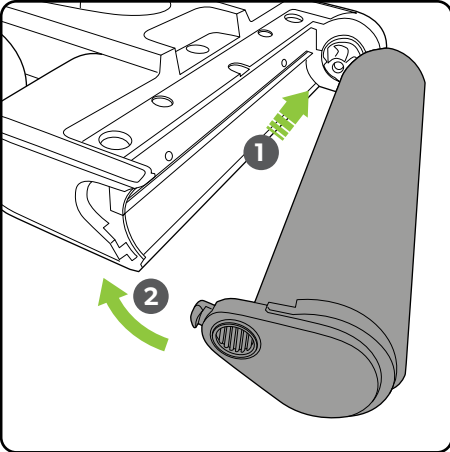

Locate the end of the roller onto head and then push the end cap until it clicks into place.

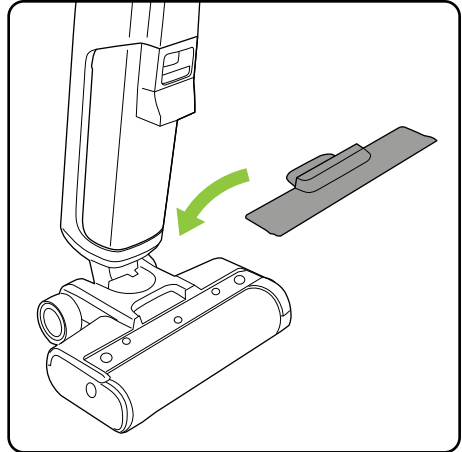

Refit the roller cover.

Clearing blockages

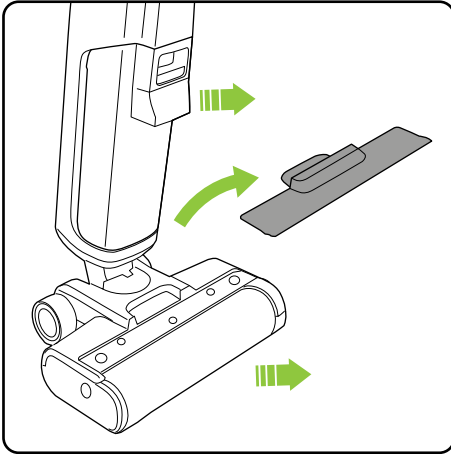

If the cleaning performance is low the Orca may have become blocked. To check for blockages remove the waste water tank, roller cover, and mopping roller.

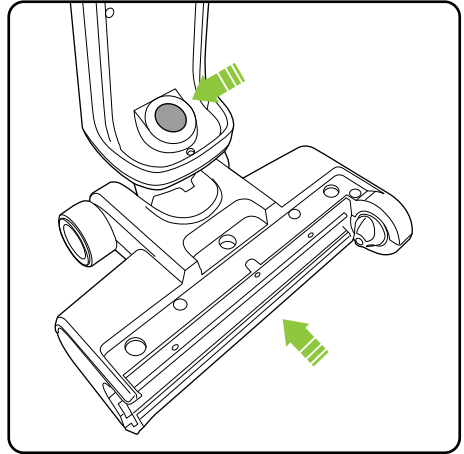

Check for any blockages in the cleaning head inlet and tube.

Product care

Your product doesn't need much maintenance: keep the water tanks, mopping roller, and filter clean and charge the battery. Wipe it with a dry cloth if it gets dirty, including under the bin.

To maintain optimum battery life store the product in clean, dry conditions, within a recommended temperature range of 0 - 25°C. Do not store the product in areas of high temperature above 25°C. Do not store near a source of heat or where exposed to direct sunlight.

If the product will be stored for longer periods of time without use it is recommended to fully charge the battery before storage to help maintain its condition and life.

Product support

If these initial tips do not solve your problem we please visit our support area where you can find troubleshooting help including online manuals, FAQs and how-to-videos, as well as genuine spares and replacement parts compatible with your product.

Visit: www.gtech.co.uk/support



Online



Live chat support



support@gtech.co.uk



How to Videos

Troubleshooting

Problem	Possible cause	Solution
The product does not turn on	Battery is fully discharged.	Charge the product.
	Handle in park position.	Pull the handle back to release and operate.
Product is not cleaning well	The dirty water in waste water tank has reached the MAX line.	Empty the dirty water and then reinstall the waste water tank.
	The filter in the waste water tank is dirty.	Clean the filter.
	Blockage in the cleaning head or air path.	Remove the mopping roller and waste water tank and check for blockages.
	Mopping roller malfunction.	Check mopping roller is correctly fitted. Clean and/or replace mopping roller.
	Roller cover missing or not well fitted.	Check roller cover is correctly fitted.
Abnormal noise	Blockage in the cleaning head or air path.	Remove the mopping roller and waste water tank and check for blockages.
	The dirty water in waste water tank has reached the MAX line.	Empty the dirty water and then reinstall the waste water tank.
Product won't charge	The charger is not designed for this product	Use the original charger.
	Poor electrical connection.	Check the charger is correctly plugged into the charging stand and mains supply. Check wall socket is switched on. Try another wall socket.
	Product is not located well on charging stand.	Check product is well positioned on the charging stand. Check the charger cord is not trapped under the product.

TECHNICAL SPECIFICATION

Battery	25.2V Li-Ion
Charging period	5 hours
Battery charger output	31V DC 0.75A
Weight	4.1kg

Product Recycling

Many of the electrical items that are thrown away can be repaired or recycled, saving natural resources and helping to protect the environment.

Gtech products are marked with the  symbol indicating they can be recycled, and are covered by legislation for Waste Electrical and Electronic Products (2012/19/EU)

When the product has reached the end of its life both it and the Li-Ion battery it contains should not be disposed of with general household waste. The battery should be removed from the product and both should be disposed of separately at a recognised recycling centre.

Recycling electrical products and batteries is free at your local recycling centre.

To find your nearest centre and discover how easy it is to recycle electrical products visit www.recycle-more.co.uk

Alternatively contact your local council or civic amenity site.



FOR HOUSEHOLD USE ONLY

WARRANTY – REGISTRATION

Visit www.gtech.co.uk/warrantyregistration to register your product and ensure that we have all the information required to provide you with quick and efficient support.

You will need your product's serial number. You can find this behind the water tank.

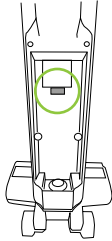

If you purchased directly from Gtech, your details are already registered and your 2-year warranty will start automatically.

If you purchased from an authorised Gtech retailer, please register your warranty within 3 months.

You will need to provide proof of purchase to support any claim(s) against your warranty.

WARRANTY – TERMS AND CONDITIONS

If your product is within its warranty and has a fault that cannot be resolved from the troubleshooting section or online support, please do the following:

- Contact our Gtech Customer Care Helpline on UK: 08000 308 794, who will go through any troubleshooting with you to identify the fault.
- If your fault can be resolved by a replacement part, this will be sent to you free of charge.
- Following troubleshooting, if your product needs to be replaced, we will arrange collection of your faulty product for inspection, and delivery of a replacement product free of charge.

Your product is guaranteed against material or manufacturing faults for 2 years from the date of purchase (or the delivery date if this is later) subject to the following terms and conditions:

SUMMARY

The guarantee becomes effective at the date of purchase (or the date of delivery if this is later). If a product is repaired or replaced during the warranty period, the warranty period is not started again.

- You must provide proof of delivery/purchase before any work can be carried out on the product. Without this proof, any work carried out will be chargeable. Please keep your receipt or delivery note.
- All work will be carried out by Gtech or its authorised agents.
- Any parts which are replaced will become the property of Gtech.
- The repair or replacement of your product is under guarantee and will not extend the period of guarantee.
- The guarantee provides benefits which are additional to and do not affect your statutory rights as a consumer.

WHAT ISN'T COVERED

Gtech does not guarantee the repair or replacement of a product as a result of:

- Normal wear and tear (e.g. cleaning fluid) .
- Use of consumables (e.g cleaning solution)
- Accidental damage, faults caused by negligent use or lack of care and maintenance, misuse, neglect, careless operation or handling of the product which is not in accordance with operating manual.
- Blockages. Please refer to the operating manual for details of how to unblock your product.
- Use of the product for anything other than the normal domestic household purposes.
- Use of parts and accessories which are not Gtech genuine components.
- Faulty installation (except where installed by Gtech)
- If it is modified in any way.
- Repairs or alterations carried out by parties other than Gtech or its authorised agents.
- Purchasing your product from an unofficial third party (i.e not from Gtech or an official Gtech retailer.
- If you are in doubt as to what is covered by your guarantee, please call the Gtech Customer Care Helpline on UK: 08000 308 794

International orders are subject to a delivery charge for both faulty and non faulty products.

Notes



Grey Technology Limited

Brindley Road, Warndon, Worcester WR4 9FB, UK

email: support@gtech.co.uk

telephone: 08000 308 794

www.gtech.co.uk