

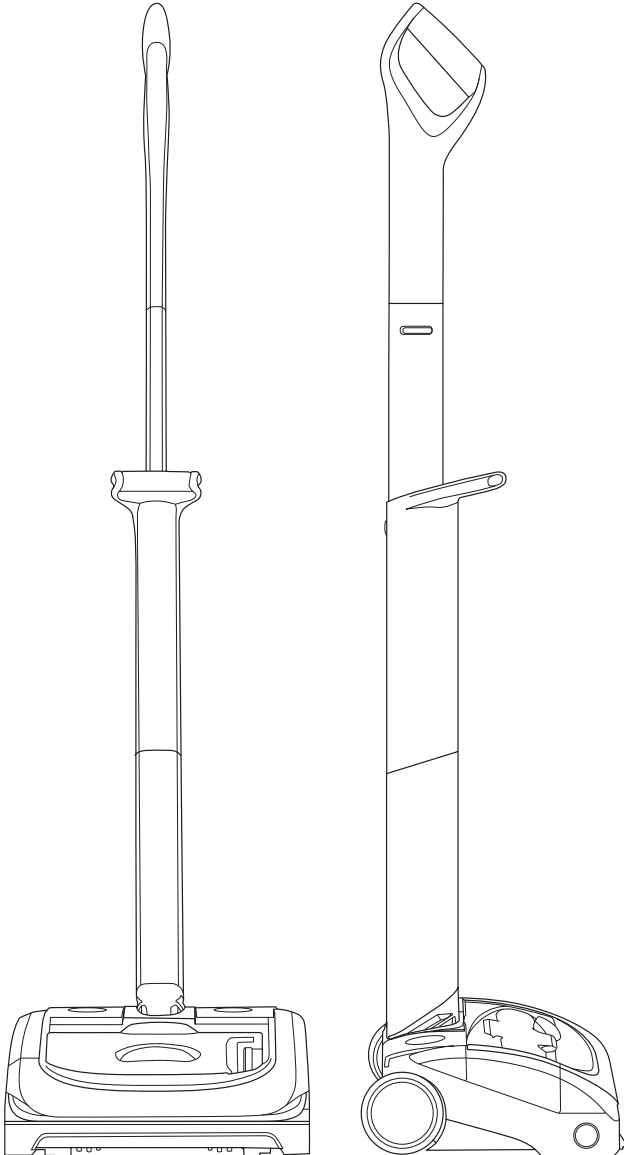

AirRAM

Model number:
AR Series



OPERATING MANUAL

IMPORTANT SAFEGUARDS:



**IMPORTANT: READ ALL INSTRUCTIONS BEFORE USE.
RETAIN INSTRUCTIONS FOR FUTURE REFERENCE.**



Do not use in rain or leave outdoors whilst raining.



WARNING: Basic safety precautions should always be observed when using an electrical appliance, including the following to reduce the risk of fire, electrical shock, or injury:

Personal Safety:

- Store indoors in a dry place out of the reach of children.
- Always use responsibly. This appliance can be used by children aged from 8 years and above and persons with reduced physical, sensory or mental capabilities or lack of experience and knowledge if they have been given supervision or instruction concerning use of the appliance in a safe way and understand the hazards involved.
- Don't let children play with the appliance; supervise children using or maintaining the appliance.
- Use only manufacturer's recommended attachments as described in this manual; misuse or use of any accessory or attachment other than those recommended, may present a risk of personal injury.
- Take extra care when cleaning stairs.
- Keep the appliance and accessories away from hot surfaces.
- Do not block the appliances openings or hinder air flow; keep openings free of any objects including dust, lint, clothing, fingers (and all parts of the body).
- Particularly keep hair away from openings and moving parts.

Electrical safety:

- Only use batteries and chargers supplied by Gtech.
- Never modify the charger in any way.
- The charger has been designed for a specific voltage. Always check that the mains voltage is the same as that stated on the rating plate.

A charger that is suitable for one type of battery pack may create a risk of fire when used with another battery pack; never use the charger with another appliance or attempt to charge this product with another charger.

- Before use, check the charger cord for signs of damage or ageing. A damaged or entangled charger cord increases the risk of fire and electric shock.
- Do not abuse the charger cord.
- Never carry the charger by the cord.
- Do not pull the cord to disconnect from a socket; grasp the plug and pull to disconnect.
- Don't wrap the cord around the charger when storing.
- Keep the charger cord away from hot surfaces and sharp edges.
- The supply cord cannot be replaced. If the cord is damaged the charger should be discarded and replaced.
- Do not handle the charger or the appliance with wet hands.
- Do not store or charge the appliance outdoors.
- The charger must be removed from the socket before removing the battery, cleaning or maintaining the appliance.

Battery safety:

- This appliance includes Li-Ion batteries; **do not incinerate batteries or expose to high temperatures**, as they may explode.
- Liquid ejected from the battery may cause irritation or burns.
- In an emergency situation contact professional help immediately!

- Leaks from the battery cells can occur under extreme conditions. Do not touch any liquid that leaks from the battery. If the liquid gets on the skin wash immediately with soap and water. If the liquid gets into the eyes, flush them immediately with clean water for a minimum of 10 minutes and seek medical attention. Wear gloves to handle the battery and dispose of immediately in accordance with local regulations.
- Shorting the battery terminals may cause burns or fire.
- When the battery pack is not in use, keep it away from paper clips, coins, keys, nails, screws or other small metal objects that could make a connection from one terminal to another.
- Store the battery away from any liquids and chemicals that may damage the battery and cause a risk of fire.
- Store the battery in clean, dry conditions, within a recommended temperature range of 0 - 25°C
- Do not store the battery in areas of high temperature above 25°C. Do not store near a source of heat or where exposed to direct sunlight.
- When you dispose of the appliance remove the battery and dispose of the battery safely in accordance with local regulations.

Service:

- Before using the appliance and after any impact, check for signs of wear or damage and repair as necessary.
- Do not use the appliance if any part is damaged or defective.
- Repairs should be carried out by a service agent or a suitably qualified person in accordance with relevant safety regulations. Repairs by unqualified persons could be dangerous.
- Never modify the appliance in any way as this may increase the risk of personal injury.
- Only use replacement parts or accessories provided or recommended by Gtech.

Intended use:

- This appliance has been designed for domestic dry vacuum cleaning only.
- Do not pick up liquids or use on wet surfaces.
- Do not pick up anything that is flammable, burning or smoking.
- Use only as described in this manual.
- Don't use on concrete, tarmacadam or other rough surfaces.
- The brush bar may damage certain floor surfaces. Before vacuuming flooring, rugs or carpets, check the flooring manufacturer's recommended cleaning instructions.
- The product may damage delicate fabrics or upholstery. Care should be taken on loose-weave carpets and coverings or where there are loose threads. It is advised to test on an inconspicuous area first before use.
- The product has been designed to clean a wide variety of floor surfaces without the need to change settings. However some surfaces such as delicate loose-pile rugs or carpets, tasselled rug edges or damaged carpets with exposed threads are not suitable for cleaning with a rotary brush.
- The product has a constantly rotating brush bar. Never leave the cleaning head in one spot for an extended period of time as this may damage the floor surface.
- Particularly for hard flooring, before vacuuming check the area being cleaned is free of any hard debris or objects that could damage the flooring if caught underneath the product, and that the underside of the product is free from foreign objects that could mark the surface.

WARNING:

- **Do not use water, solvents, or polishes to clean the outside of the appliance; wipe clean with a dry cloth.**
- **Never immerse the unit in water and do not clean in a dish washer.**
- **Never use the appliance without the filter fitted.**



Thank you for choosing Gtech

"Welcome to the Gtech family. I started Gtech to create sensible, easy to use products that do a great job, and hope you get many years of trouble-free performance from your new product."

Nick Grey – Inventor, owner of Gtech

Make a note of your product serial number code for future reference. You can find this on the underside of item **1**

---~
---~
---~
---~

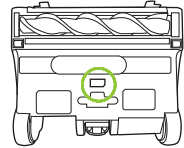

What's in the box

- 1** Head full assembly
- 2** Lower Handle
X 2 components
- 3** Upper Handle
X 2 components
- 4** Charger
- 5** Hair removal tool

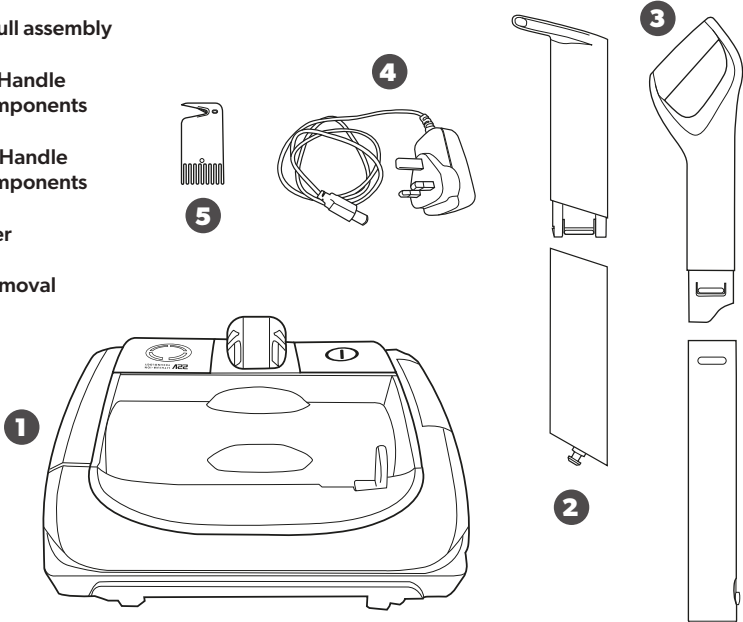

Assembly

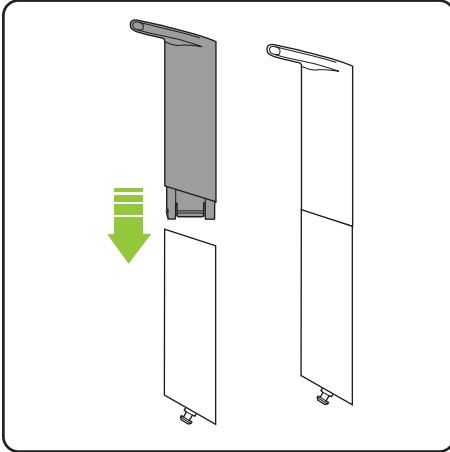

Push the two parts of the lower handle together in the orientation shown above. They will only fit one way. They will click into place and remain permanently fixed.

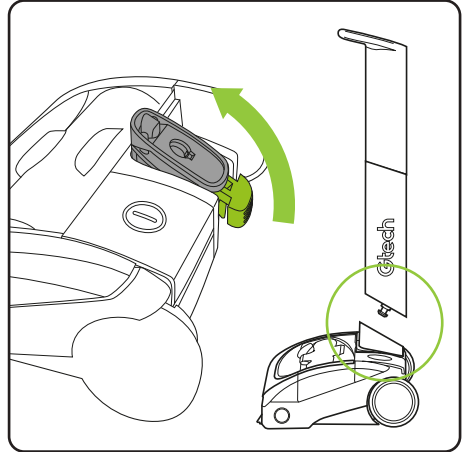

Push the pivot poke to the upright position. This might require some force. Attach the lower handle to the head assembly (See next step)

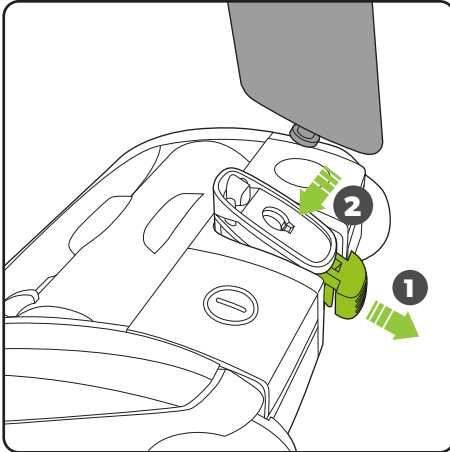

Pull out the locking clip to allow the lower handle to fit (the clip remains attached to the head) Insert the metal pin on the lower handle into the hole in the pivot yoke.

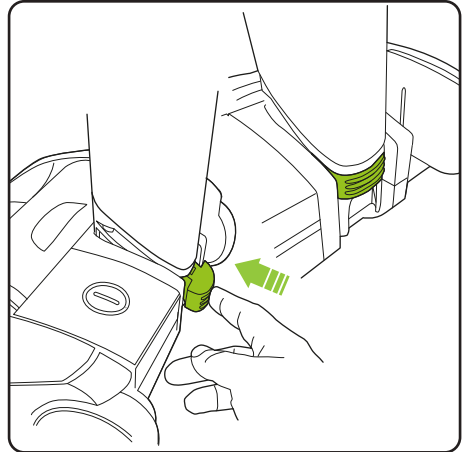

Ensure the lower handle is sitting completely flush against the pivot yoke. Firmly push the locking clip until it clicks fully into place. The clip can be pulled out to unlock the lower handle should it need to be removed.

Assembly (continued)

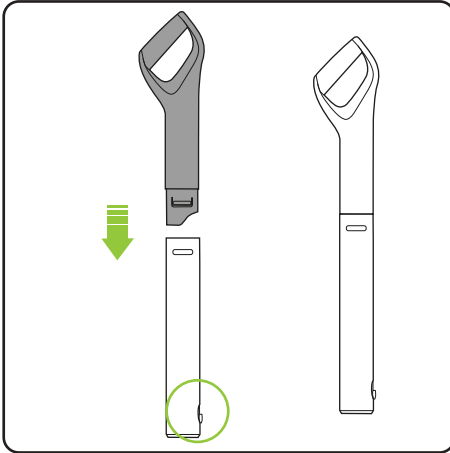

Push the two parts of the upper handle together in the orientation shown above. They will only fit one way. They will click into place and remain permanently fixed.

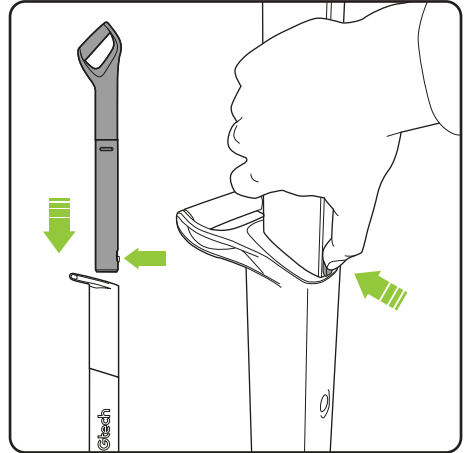

Insert the upper handle into the lower handle. You will need to press the button on the upper handle to fit it in. Once it slides down you will hear it click into place.

Storage

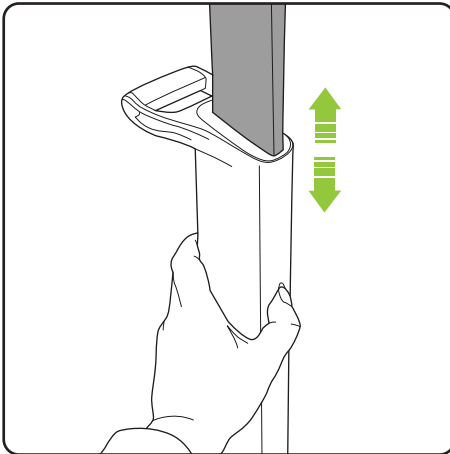

To stow or extend the upper handle simply press the button on the lower handle to unlock the upper handle. The upper handle will now slide up or down depending on required position.

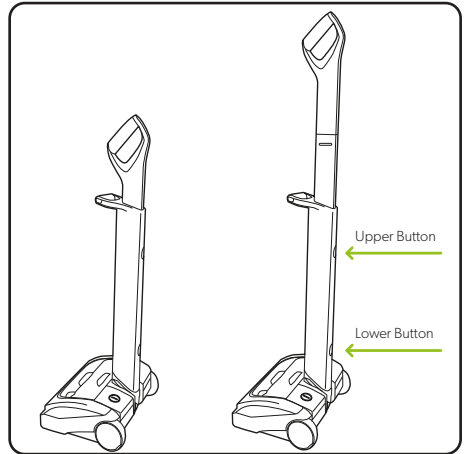

The upper handle can be set in two positions: Lowered for storage and raised for use. To lower the handle, release the upper button. To raise the handle from the stored position, release the lower button.

Operation

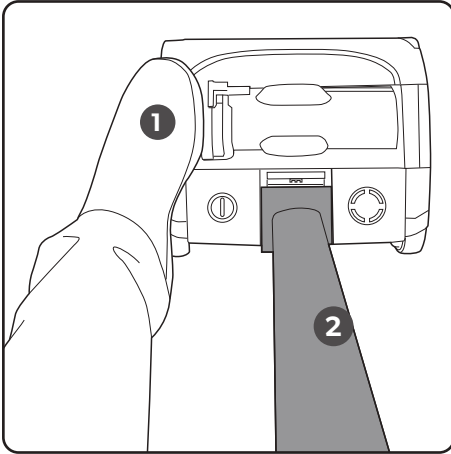

Without pressing the power button, place your foot on the left side of the head (1) and pull the handle back (2).

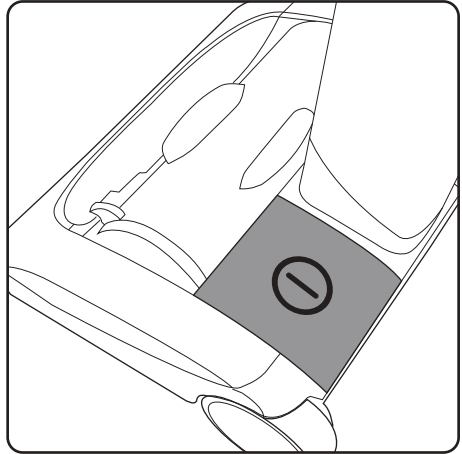

The power button is located on the left hand side of the head assembly.

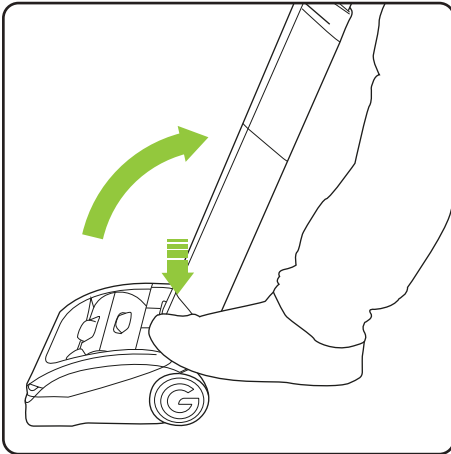

Press the power button with your foot to turn the product on.

Battery charging

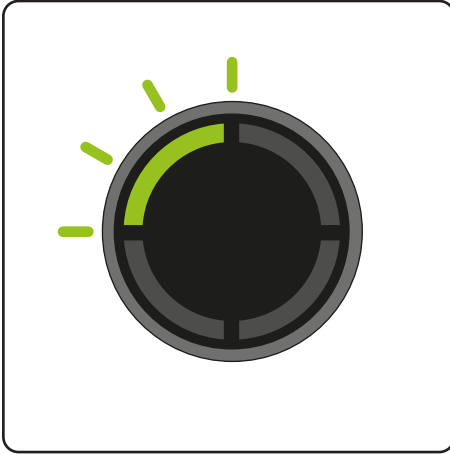

When the state of charge indicator starts to flash one green LED, recharge the battery.

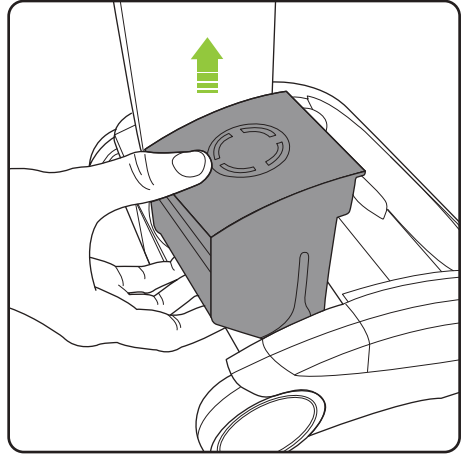

To remove the battery, squeeze the latch underneath and pull upwards.

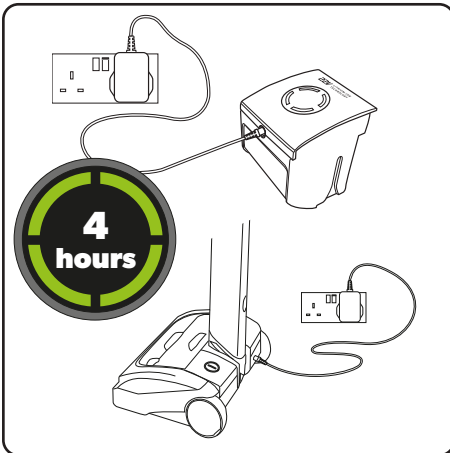

The battery can be charged whilst it's in the product, or when it's off the product. The battery can be charged from flat in 4 hours. The state of charge indicator will show 4 solid green lights when it is charged.

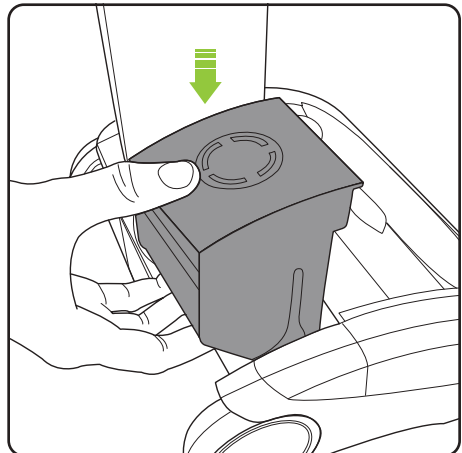

It is OK to charge for 1 hour for a burst of cleaning. Replace the battery by sliding it down into the head assembly. It will click into place.

Emptying the bin

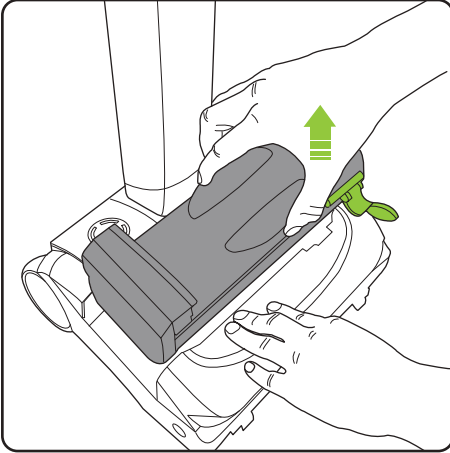

Holding onto the product with one hand, pull the bin handle and lift the bin out of the product.

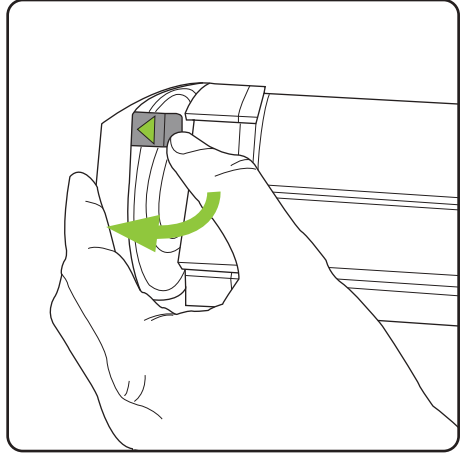

Lift and release the latch marked with the green arrow to pull open the lid.

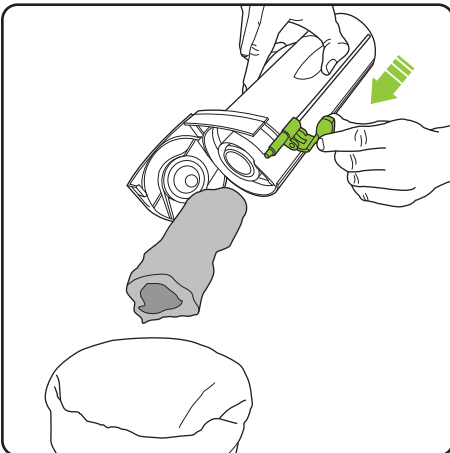

Hold the product's bin over a rubbish bin and push the green lever towards the lid to empty the dirt.

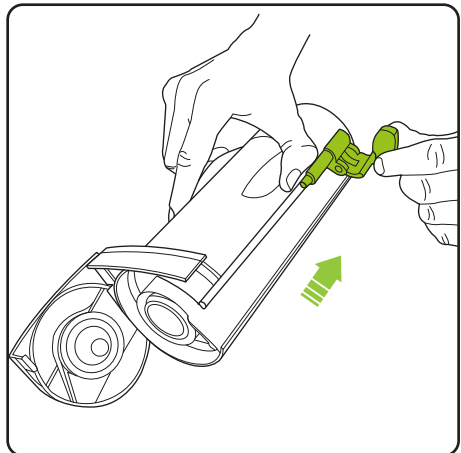

Pull the green lever back towards the bottom of the bin. Close the bin lid and reinsert the bin into the product.

Cleaning the filters - do this once a month or more frequently depending on use.

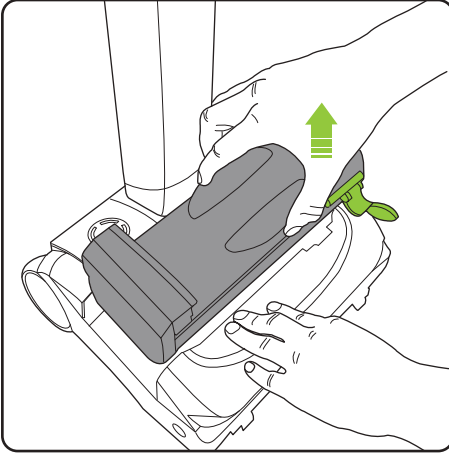

Holding onto the product with one hand, pull the bin handle and lift the bin out of the product.

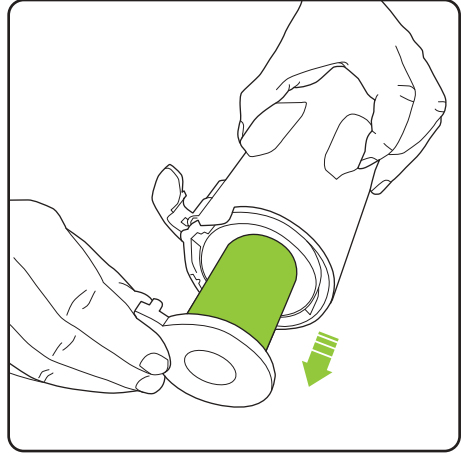

Pull the filter out of the filter housing. Tap the dirt from the filter and tip any dirt from the filter housing. Wash the filter if necessary.

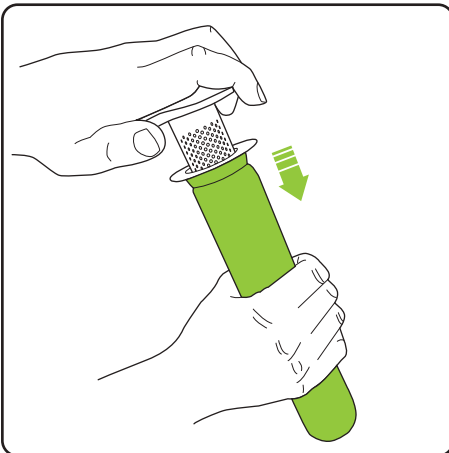

Remove the filter from the inner shroud, by twisting and pulling. Tap the inner shroud over a bin to remove any excess dirt.

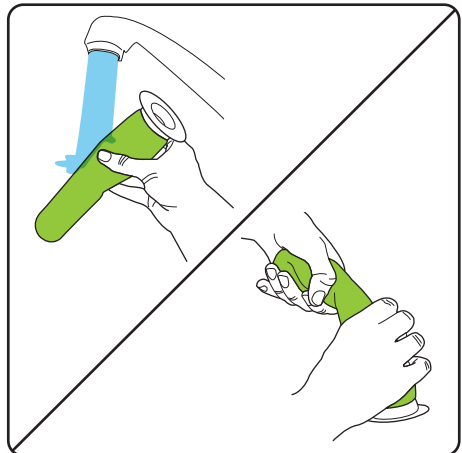

Wash the filter under a tap. Squeeze out any excess water then let it **dry completely** before reinserting into the product. Recommended water temperature 40°C. Do not use detergent or soaps. **Never put bin back without filter inside. You could damage the motor.**

Replacing the filters

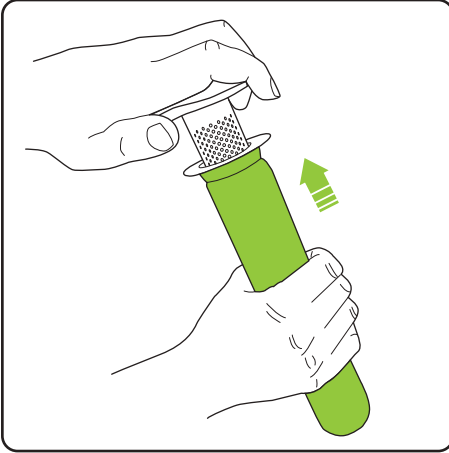

Slide the filter onto the inner shroud.

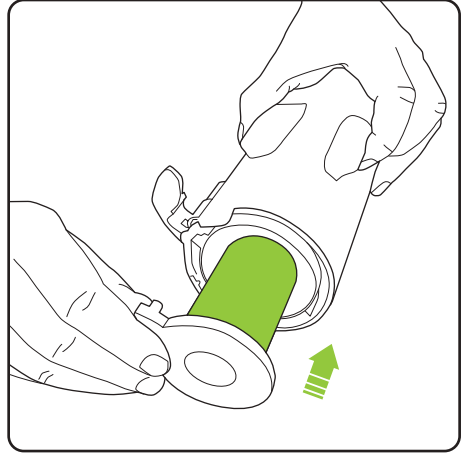

Slide the filter and inner shroud into the filter housing.

Removing and cleaning the brush bar / jam or fault

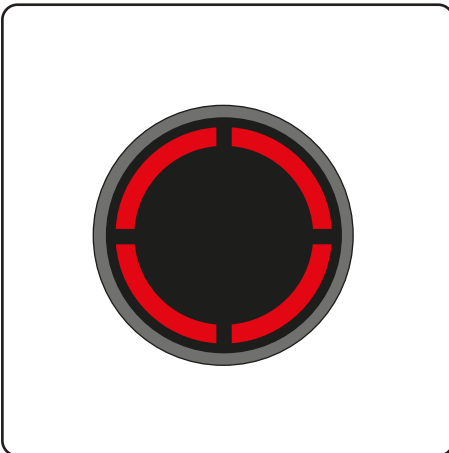

If the brush bar jams during use, the product will stop and the LEDs will appear red. You will need to remove and clean the brush bar.

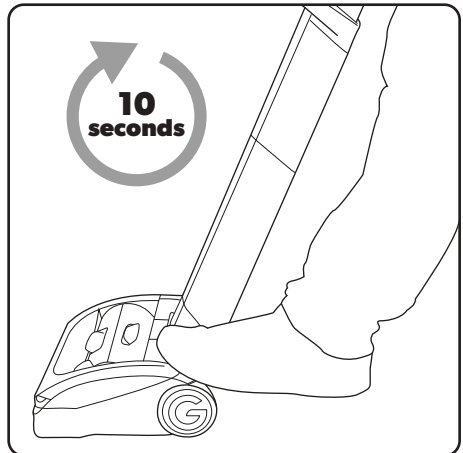

The product will not re-start until the red lights go out. This will take ten seconds.

If the problem persists, follow the troubleshooting instructions on page 14.

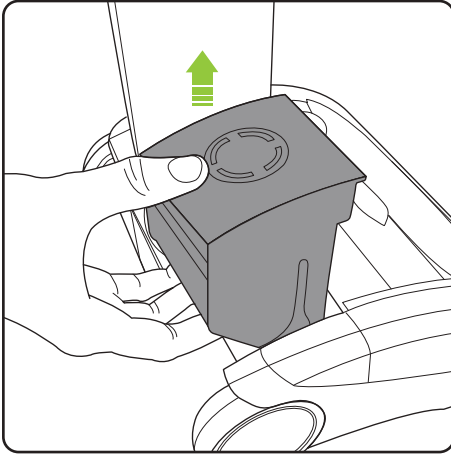

Before checking for a blockage, remove the battery.

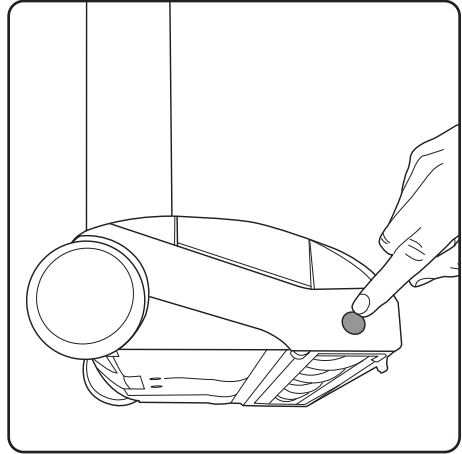

Rest the product on its side and locate the brush bar button on the right hand side. Press the button inwards and then pull the brush bar out from the bottom of the product.

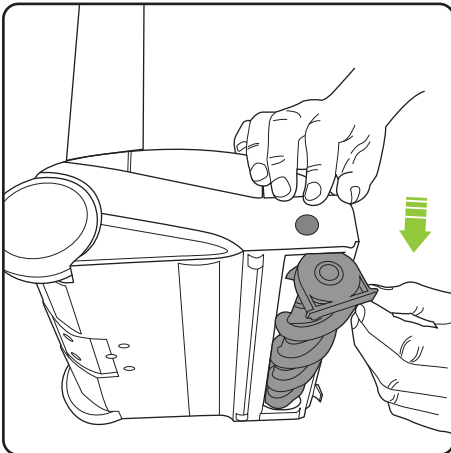

The brush bar can now be removed, starting at the button end.

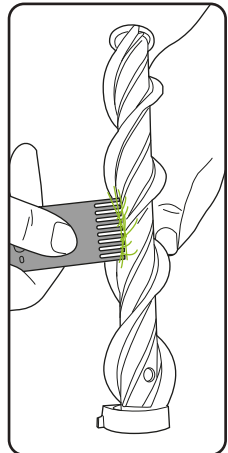
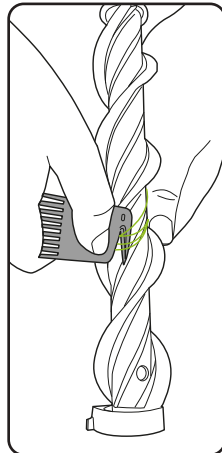

To remove hair from the brush bar, run the hair removal tool down the groove to cut the hair, then use the comb remove it. Never operate the product without the brush bar in place.

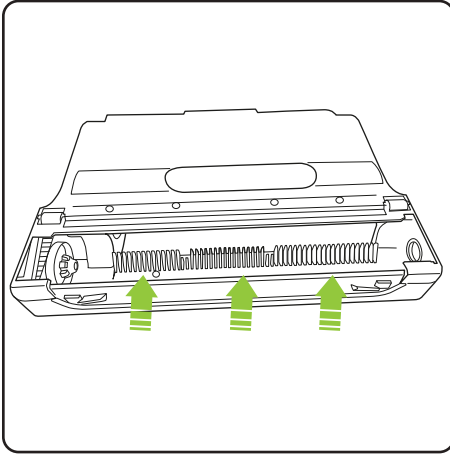

While the brush bar is removed you can take the opportunity to remove any hair from the brush bar housing comb as indicated.

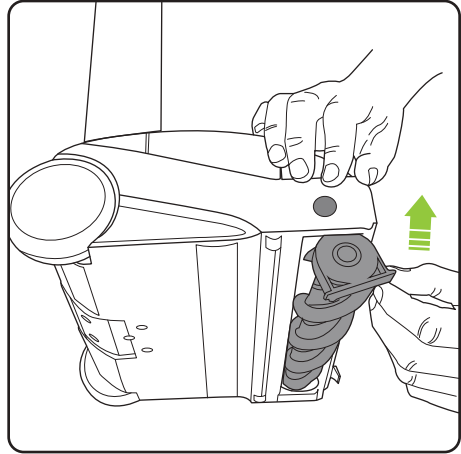

Re-insert the brush bar, starting by the end furthest away from the button. Then line up and push the brush bar into the product until it clicks into place.
Replace the battery.

AIRRAM TECHNICAL SPECIFICATION

Battery model	103A022
Battery	22V Li-Ion
Charging period	4 hours
Battery charger output	27V DC 500mA
Weight	3.2kg

Product Recycling

Many of the electrical items that are thrown away can be repaired or recycled, saving natural resources and helping to protect the environment.

Gtech products are marked with the  symbol indicating they can be recycled, and are covered by legislation for Waste Electrical and Electronic Products (2012/19/EU)

When the product has reached the end of its life both it and the Li-Ion battery it contains should not be disposed of with general household waste. The battery should be removed from the product and both should be disposed of separately at a recognised recycling centre.

Recycling electrical products and batteries is free at your local recycling centre.

To find your nearest centre and discover how easy it is to recycle electrical products visit www.recycle-more.co.uk

Alternatively contact your local council or civic amenity site.



FOR HOUSEHOLD USE ONLY



Product care

Your product doesn't need much maintenance: keep the filters clean, keep the brush bar tangle-free and charge the battery. Wipe it with a dry cloth if it gets dirty, including under the bin.

To maintain optimum battery life store the battery in clean, dry conditions, within a recommended temperature range of 0 - 25°C. Do not store the battery in areas of high temperature above 25°C. Do not store near a source of heat or where exposed to direct sunlight.

If the product will be stored for longer periods of time without use it is recommended to fully charge the battery before storage to help maintain its condition and life.

Troubleshooting

Product is not cleaning well		<ol style="list-style-type: none">1. Empty the bin2. Check bin is correctly fitted3. Check filter is correctly fitted4. Clean and/or replace filter5. Check brush bar fitment6. Clean and/or replace brush bar
Product has stopped or won't work – 1 flashing green LED		<ol style="list-style-type: none">1. Battery is fully discharged2. Recharge the battery
Product has stopped or won't work – 4 solid red LEDs		<ol style="list-style-type: none">1. The brush bar is blocked or jammed2. Clear debris from the brush bar (see p.11-13)
Battery will not charge		<ol style="list-style-type: none">1. Check the charger is correctly connected to the battery and mains supply2. Check wall socket is switched on3. Try another wall socket

Product support

If these initial tips do not solve your problem we please visit our support area where you can find troubleshooting help including online manuals, FAQs and how-to-videos, as well as genuine spares and replacement parts compatible with your product.

Visit: www.gtech.co.uk/support



Online



support@gtech.co.uk



How to Videos

WARRANTY – REGISTRATION

Visit www.gtech.co.uk/warrantyregistration to register your product and ensure that we have all the information required to provide you with quick and efficient support.

You will need your product's serial number.

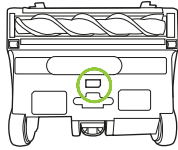

If you purchased directly from Gtech, your details are already registered and your 2-year warranty will start automatically.

If you purchased from an authorised Gtech retailer, please register your warranty within 3 months. You will need to provide proof of purchase to support any claim(s) against your warranty.

WARRANTY – TERMS AND CONDITIONS

If your product is within its warranty and has a fault that cannot be resolved from the troubleshooting section or online support, please do the following:

- Contact our Gtech Customer Care Helpline on UK: 08000 308 794, who will go through any troubleshooting with you to identify the fault.
- If your fault can be resolved by a replacement part, this will be sent to you free of charge.
- Following troubleshooting, if your product needs to be replaced, we will arrange collection of your faulty product for inspection, and delivery of a replacement product free of charge.

Your product is guaranteed against material or manufacturing faults for 2 years from the date of purchase (or the delivery date if this is later) subject to the following terms and conditions:

SUMMARY

The guarantee becomes effective at the date of purchase (or the date of delivery if this is later). If a product is repaired or replaced during the warranty period, the warranty period is not started again.

- You must provide proof of delivery/purchase before any work can be carried out on the product. Without this proof, any work carried out will be chargeable. Please keep your receipt or delivery note.
- All work will be carried out by Gtech or its authorised agents.
- Any parts which are replaced will become the property of Gtech.
- The repair or replacement of your product is under guarantee and will not extend the period of guarantee.
- The guarantee provides benefits which are additional to and do not affect your statutory rights as a consumer.

WHAT ISN'T COVERED

Gtech does not guarantee the repair or replacement of a product as a result of:

- Normal wear and tear (e.g. drive belt, brush bar, batteries) .
- Use of consumables (e.g. dust bags and cartridges)
- Accidental damage, faults caused by negligent use or lack of care and maintenance, misuse, neglect, careless operation or handling of the product which is not in accordance with operating manual.
- Blockages. Please refer to the operating manual for details of how to unblock your product.
- Use of the product for anything other than the normal domestic household purposes.
- Use of parts and accessories which are not Gtech genuine components.
- Faulty installation (except where installed by Gtech)
- If it is modified in any way.
- Repairs or alterations carried out by parties other than Gtech or its authorised agents.
- Purchasing your product from an unofficial third party (i.e. not from Gtech or an official Gtech retailer).
- If you are in doubt as to what is covered by your guarantee, please call the Gtech Customer Care Helpline on UK: 08000 308 794

International orders are subject to a delivery charge for both faulty and non faulty products.



Grey Technology Limited

Brindley Road, Warndon, Worcester WR4 9FB, UK

email: support@gtech.co.uk

telephone: 08000 308 794

www.gtech.co.uk